

Quantrol LC100 / LC200 / LC300

Universal PID Controller Series

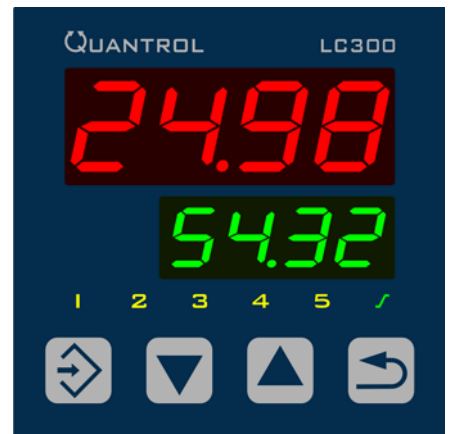

B 702020.0 Operating Manual

1	Introduction	5
1.1	Device documentation	5
1.2	Safety information	5
1.3	Scope of delivery	6
2	Installation - Electrical Connection	7
2.1	Identifying the device version	7
2.2	Excerpt from the technical data	7
2.3	Installation	9
2.4	Installation notes	10
2.5	Electrical isolation	10
2.6	Connection diagram	11
3	Operation - Configuration - Parameterization	13
3.1	Operation	13
3.1.1	Display and operating elements	13
3.1.2	Self-optimization, setpoint and manual mode	13
3.1.3	Ramp function/firing curve	13
3.1.4	Level concept	14
3.1.5	Operator level (OPR)	14
3.2	Configuration (CONF)	15
3.2.1	Analog input (InP)	15
3.2.2	Controller (Cntr)	16
3.2.3	Ramp function/firing curve (rAFC)	17
3.2.4	Limit value monitoring (Li1, Li2)	17
3.2.5	Timer (tFCt)	18
3.2.6	Outputs (OutL, OutA)	19
3.2.7	Binary functions (binF)	20
3.2.8	Display and operation (diSP)	20
3.2.9	Interface (IntF)	21
3.3	Parameterization (PARA)	22
4	Supplement	23
4.1	Additional information about installation	23
4.1.1	Device representation including dimensions	23
4.1.2	Cleaning the device front	25
4.2	Additional information about the device functions	26
4.2.1	Entries and operator prompting	26
4.2.2	Analog input	27
4.2.3	Analog output	27
4.2.4	Ramp function and firing curve	28
4.2.5	Timers	29
4.2.6	Limit value monitoring	30

4.2.7	Self-optimization (TUNE)	30
4.3	Error messages	33
4.4	Technical Data	34

1.1 Device documentation

Product sheet PR 70085 (as a PDF document)

The product sheet contains general information about the device and forms the basis for planning and purchase decision.

Brief instructions B 702020.7 (printed in DIN A3 format)

These brief instructions contain the most important information about installation, the electrical connection as well as operation, parameterization and configuration of the device. The brief instructions are supplied with every device. For further information, please refer to the operating manual B 702020.0 available as a PDF document.

Operating manual B 702020.0 (as a PDF document)

This operating manual contains all information about installation, the electrical connection as well as operation, parameterization and configuration of the device.

Interface description B 702020.2.0 (as a PDF document)

It contains information about the RS485 interface, the Modbus protocol and the communication with other devices.

All PDF documents can be downloaded under www.quantrol.org.

1.2 Safety information

This manual contains information that must be observed in the interest of your own safety and to avoid damage to assets. This information is supported by symbols which are used in this manual as follows.

Please read this manual before starting up the device. Keep the manual in a place accessible to all users at all times.

All necessary settings are described in this manual. Manipulations not described in this manual or expressly forbidden will jeopardize your warranty rights.

Warning signs



DANGER!

This symbol indicates that **Injury or death caused by electrical shock** can occur, if the respective protective measures have not been taken.



CAUTION!

This symbol in combination with the signal word indicates that **damage to assets or data loss** will occur if suitable precautions are not taken.

Note signs



TIP!

This symbol refers to **Important information** about the product or its handling or additional use.

1 Introduction



REFERENCE!

This symbol refers to **Further information** in other sections, chapters or manuals.

1.3 Scope of delivery

- Controller (including seal and fastening elements)
- Brief instructions B 702020.7 in DIN A3 format

2 Installation - Electrical Connection

2.1 Identifying the device version

	Basic type																																														
702021	QUANTROL LC100 (format 48 mm x 48 mm)																																														
702022	QUANTROL LC200 (format 48 mm x 96 mm, portrait format)																																														
702024	QUANTROL LC300 (format 96 mm x 96 mm)																																														
	All types including 1 analog input (universal), 1 binary input (for potential-free contact; can be used as an alternative to analog input 0 to 10 V), 1 relay output (N/O)																																														
	<table border="1"> <tr> <td></td> <td>Basic type extension</td> </tr> <tr> <td>8</td> <td>Standard, with factory settings</td> </tr> <tr> <td>9</td> <td>Customer-specific programming (on request)</td> </tr> <tr> <td></td> <td> <table border="1"> <tr> <td>1</td> <td>2</td> <td>3</td> <td>4</td> <td>Options (3 and 4 not for LC100)</td> </tr> <tr> <td>0</td> <td>0</td> <td>0</td> <td>0</td> <td>-</td> </tr> <tr> <td>1</td> <td>1</td> <td>1</td> <td>1</td> <td>1 relay output (N/O)</td> </tr> <tr> <td>2</td> <td>2</td> <td>2</td> <td>2</td> <td>1 logic output</td> </tr> <tr> <td>3</td> <td>-</td> <td>-</td> <td>-</td> <td>1 analog output (configurable)</td> </tr> <tr> <td>-</td> <td>4</td> <td>-</td> <td>-</td> <td>1 RS485 interface</td> </tr> </table> </td> </tr> <tr> <td></td> <td> <table border="1"> <tr> <td></td> <td>Voltage supply</td> </tr> <tr> <td>23</td> <td>AC 110 to 240 V +10/-15 %, 48 to 63 Hz</td> </tr> <tr> <td>25</td> <td>AC/DC 20 to 30 V, 48 to 63 Hz</td> </tr> </table> </td> </tr> </table>		Basic type extension	8	Standard, with factory settings	9	Customer-specific programming (on request)		<table border="1"> <tr> <td>1</td> <td>2</td> <td>3</td> <td>4</td> <td>Options (3 and 4 not for LC100)</td> </tr> <tr> <td>0</td> <td>0</td> <td>0</td> <td>0</td> <td>-</td> </tr> <tr> <td>1</td> <td>1</td> <td>1</td> <td>1</td> <td>1 relay output (N/O)</td> </tr> <tr> <td>2</td> <td>2</td> <td>2</td> <td>2</td> <td>1 logic output</td> </tr> <tr> <td>3</td> <td>-</td> <td>-</td> <td>-</td> <td>1 analog output (configurable)</td> </tr> <tr> <td>-</td> <td>4</td> <td>-</td> <td>-</td> <td>1 RS485 interface</td> </tr> </table>	1	2	3	4	Options (3 and 4 not for LC100)	0	0	0	0	-	1	1	1	1	1 relay output (N/O)	2	2	2	2	1 logic output	3	-	-	-	1 analog output (configurable)	-	4	-	-	1 RS485 interface		<table border="1"> <tr> <td></td> <td>Voltage supply</td> </tr> <tr> <td>23</td> <td>AC 110 to 240 V +10/-15 %, 48 to 63 Hz</td> </tr> <tr> <td>25</td> <td>AC/DC 20 to 30 V, 48 to 63 Hz</td> </tr> </table>		Voltage supply	23	AC 110 to 240 V +10/-15 %, 48 to 63 Hz	25	AC/DC 20 to 30 V, 48 to 63 Hz
	Basic type extension																																														
8	Standard, with factory settings																																														
9	Customer-specific programming (on request)																																														
	<table border="1"> <tr> <td>1</td> <td>2</td> <td>3</td> <td>4</td> <td>Options (3 and 4 not for LC100)</td> </tr> <tr> <td>0</td> <td>0</td> <td>0</td> <td>0</td> <td>-</td> </tr> <tr> <td>1</td> <td>1</td> <td>1</td> <td>1</td> <td>1 relay output (N/O)</td> </tr> <tr> <td>2</td> <td>2</td> <td>2</td> <td>2</td> <td>1 logic output</td> </tr> <tr> <td>3</td> <td>-</td> <td>-</td> <td>-</td> <td>1 analog output (configurable)</td> </tr> <tr> <td>-</td> <td>4</td> <td>-</td> <td>-</td> <td>1 RS485 interface</td> </tr> </table>	1	2	3	4	Options (3 and 4 not for LC100)	0	0	0	0	-	1	1	1	1	1 relay output (N/O)	2	2	2	2	1 logic output	3	-	-	-	1 analog output (configurable)	-	4	-	-	1 RS485 interface																
1	2	3	4	Options (3 and 4 not for LC100)																																											
0	0	0	0	-																																											
1	1	1	1	1 relay output (N/O)																																											
2	2	2	2	1 logic output																																											
3	-	-	-	1 analog output (configurable)																																											
-	4	-	-	1 RS485 interface																																											
	<table border="1"> <tr> <td></td> <td>Voltage supply</td> </tr> <tr> <td>23</td> <td>AC 110 to 240 V +10/-15 %, 48 to 63 Hz</td> </tr> <tr> <td>25</td> <td>AC/DC 20 to 30 V, 48 to 63 Hz</td> </tr> </table>		Voltage supply	23	AC 110 to 240 V +10/-15 %, 48 to 63 Hz	25	AC/DC 20 to 30 V, 48 to 63 Hz																																								
	Voltage supply																																														
23	AC 110 to 240 V +10/-15 %, 48 to 63 Hz																																														
25	AC/DC 20 to 30 V, 48 to 63 Hz																																														

/ - - **Order code**
 702024 / 8 - 3 4 1 2 - 23 **Example**

2.2 Excerpt from the technical data

Case

Case type	Plastic case for panel mounting as per IEC 61554
Dimensions (front)	LC100: 48 mm x 48 mm; LC200: 48 mm x 96 mm (portrait format); LC300: 96 mm x 96 mm
Panel cut-out	LC100: 45 mm x 45 mm; LC200: 45 mm x 92 mm; LC300: 92 mm x 92 mm
Minimum spacing horizontal / vertical	LC100: 11 mm / 30 mm (65 mm with USB cable); LC200/LC300: 22 mm / 30 mm (65 mm with USB cable)
Depth behind panel	LC100: max. 95 mm; LC200/LC300: max. 80 mm
Ambient / storage temperature range	-5 to +55 °C / -40 to +70 °C
Ambient conditions	rel. humidity < 90% annual average, without condensation

2 Installation - Electrical Connection

Operating position	any
Protection type	as per DIN EN 60529, at the front IP 65, at the rear IP 20
Weight (fully equipped)	LC100: approx. 150 g; LC200: approx. 200 g; LC300: approx. 300 g

Electrical data

Voltage supply (switch mode PSU)	AC 110 to 240V +10/-15 %, 48 to 63Hz AC/DC 20 to 30V, 48 to 63Hz
Electrical safety	as per DIN EN 61010, part 1 overvoltage category III, pollution degree 2
Power consumption	max. 14 VA
Electrical connection	on the rear via screw terminals; with core-end ferrule of a pipe shape, open cable lug or pin cable lug
Conductor cross section	fine-strand up to max. 1.5 mm ²
Tightening torque	0.5 Nm
Electromagnetic compatibility	as per DIN EN 61326-1
Interference emission	Class A - Only for industrial use -
Interference immunity	Industrial requirements
Setup interface	USB socket, type Mini-B 5-pole

2 Installation - Electrical Connection

2.3 Installation

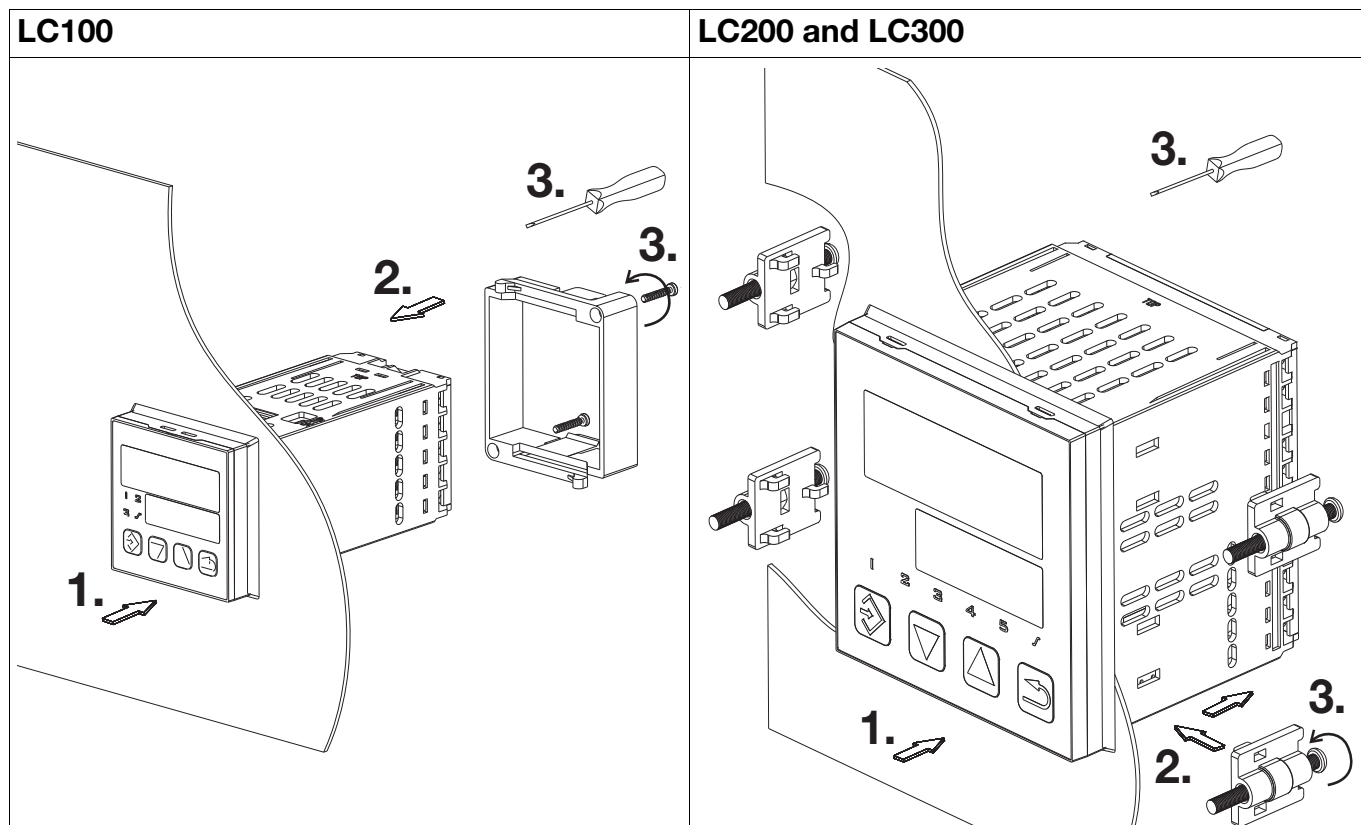

Installation of LC100	Installation of LC200 and LC300
<p>1. Insert the device from the front into the panel cut-out and ensure that the seal is correctly positioned.</p>	<p>1. Insert the device from the front into the panel cut-out and ensure that the seal is correctly positioned.</p>
<p>2. Push the fastening frame from the panel rear onto the device and press the springs against the panel rear until the lugs engage in their slots.</p>	<p>2. Slide the mounting brackets from the panel rear into the lateral openings and push to the rear against the stop.</p>
<p>3. Uniformly tighten the fastening frame screws using a screwdriver until they are sufficiently fastened.</p>	<p>3. Place the mounting brackets against the panel rear, and tighten evenly with a screwdriver.</p>

2 Installation - Electrical Connection

2.4 Installation notes

- The device is not suitable for installation in explosive areas (Ex areas).
- The choice of cable material, the installation and the electrical connection of the device must conform to the requirements of DIN VDE 0100 "Installation of low-voltage power circuits" and/or the appropriate local/national regulations (e.g. based on IEC 60364).
- The electrical connection must only be carried out by qualified personnel.
- The device is intended to be installed in electrical cabinets or systems. It shall be operated by mains protected with a branch circuitry overcurrent protection device not more than 20 Amps. For servicing/repairing a Disconnecting Device shall be provided to disconnect all conductors.
- The load circuit must be fused for the maximum relay current, in order to prevent the output relay contacts from becoming welded in the event of a short circuit occurring at that point.
- The electromagnetic compatibility (EMC) meets the standards and regulations cited in the technical data.
- Run input, output and supply cables separately and not in parallel with one another.
- Sensor and interface cables should be shielded cables with twisted conductors. Do not run cables close to current-carrying components or cables. Ground the shielding on one side.
- Do not connect other consumers to the power terminals of the device.

2.5 Electrical isolation

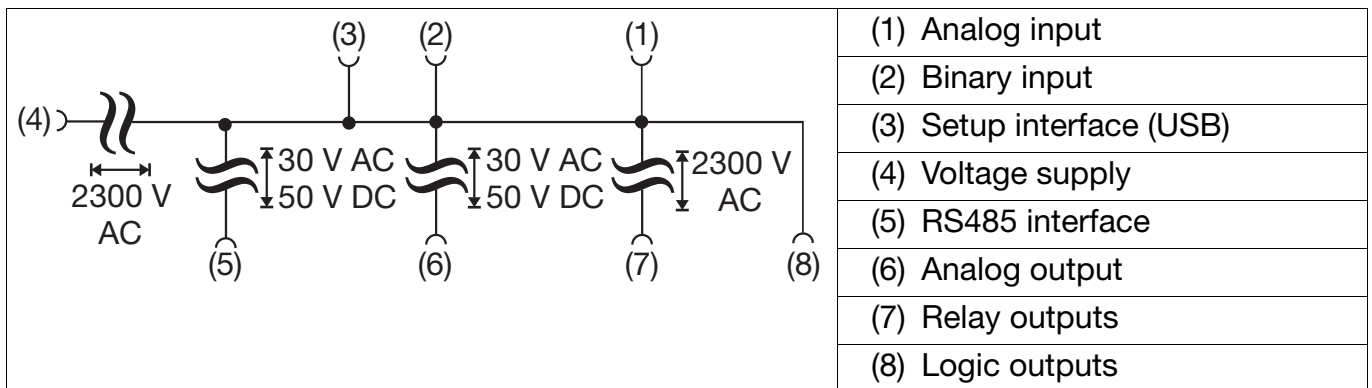

2 Installation - Electrical Connection

2.6 Connection diagram

The terminal strips on the device rear are equipped with screw terminals. Please refer to the technical data for specifications concerning the conductor cross section.

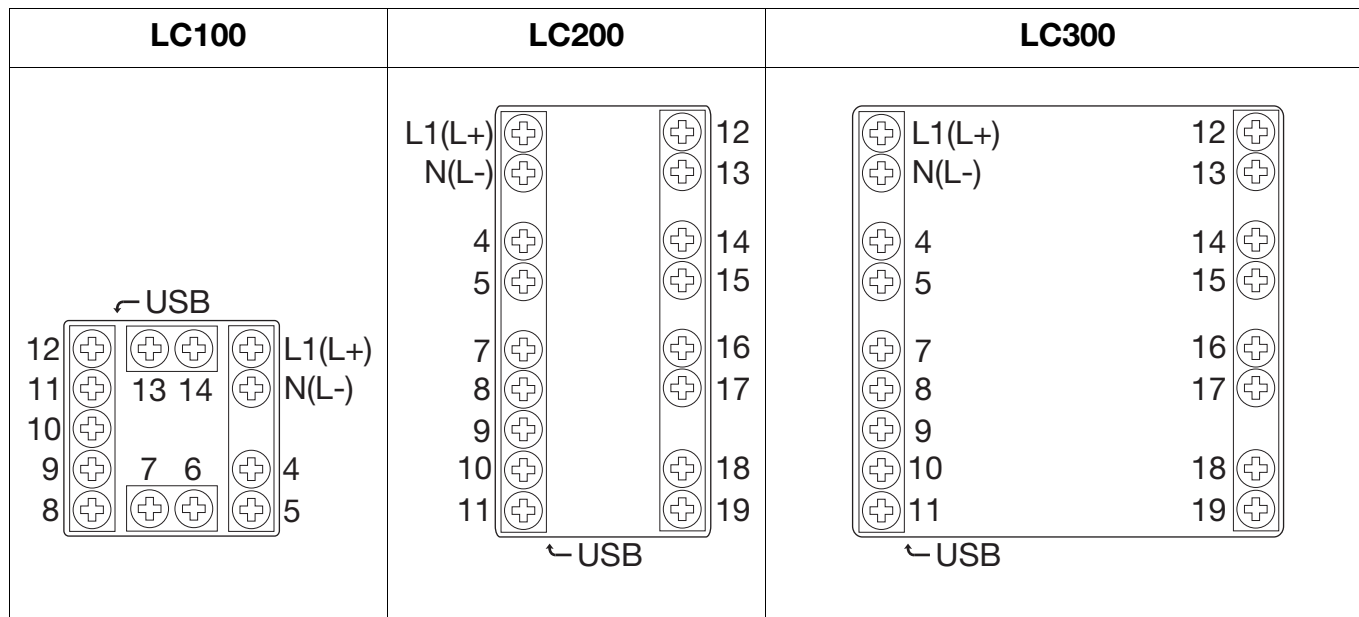

TIP!

The USB interface (socket Mini-B, 5-pole) is labeled on the device with "SETUP" and is located on the case top of the LC100 and on the case bottom of the LC200 and LC300. It is used for connection to a PC that is running the setup program.

2 Installation - Electrical Connection



DANGER!

The electrical installation may carry voltage.

Risk of electrocution.

The electrical connection must only be performed by qualified personnel.



TIP!

Prior to starting the electrical connection, check that the device version complies with the order code.

Connections	Symbol	LC100	LC200/LC300
Analog input			
Thermocouple		9 8	10 11
RTD temperature probe, 2-wire		10 8	9 11
RTD temperature probe, 3-wire		10 9 8	9 10 11
Voltage DC 0 to 10 V		12 11	7 8
Current DC 0(4) to 20 mA		9 8	10 11
Binary input for potential-free contact		11 12	7 8
	Output:	1 2 3	1 2 3 4 5
Analog output DC 0 to 10 V, DC 0(4) to 20 mA		13 14	12 13
Relay output (N/O) (max. 3 A at AC 230 V, resistive load)		4 13 6 5 14 7	4 12 14 16 18 5 13 15 17 19
Logic output (DC 0/14 V)		13 7 14 6	12 14 16 18 13 15 17 19
RS485 interface		7 6	14 15
Output 1 as standard; Outputs 2 to 5 optional (options 1 to 4)			
Voltage supply		L1 (L+) N (L-)	L1 (L+) N (L-)
Setup interface	USB socket, type Mini-B 5-pole		

3 Operation - Configuration - Parameterization

3.1 Operation

3.1.1 Display and operating elements

	(A) Programming / one level deeper
	(B) Value reduction / previous parameter
	(C) Value increase / next parameter
	(D) Function key / leave level
	(E) Red 7-segment display (factory-set: Actual value); 4-digit, configurable decimal place (automatic adjustment in the case of display overflow)
	(F) Green 7-segment display (factory-set: Setpoint); 4-digit, configurable decimal place; also display of level and parameter symbols
	(G) LED 1 to 3(5): Switching position of binary output (LED is lit = output active)
	(H) LED ramp function or firing curve

The software version is displayed on the device when simultaneously pressing keys (A) and (C).

3.1.2 Self-optimization, setpoint and manual mode

On the basis of the **Normal display**, the following **Functions** are available:

<p>Start of self-optimization: Simultaneously press keys (B) and (C) (> 2 s)</p> <p>Abort of self-optimization: Simultaneously press keys (B) and (C)</p>	<p>"tUnE" flashes in the lower display.</p> <p>No parameters are changed by the abort.</p>
<p>Change setpoint using keys (B) and (C)</p>	<p>The longer the key is kept pressed, the faster the setpoint value changes. The value will be automatically applied.</p>
<p>Function key (D) (> 2 s) is used to Change-over to manual mode and to exit the manual mode</p>	<p>The output level (%) is displayed in the lower display and can be changed with the keys (B) and (C). (The controller automatically changes to manual mode in the event of overrange/underrange and probe break.)</p>

3.1.3 Ramp function/firing curve

<p>Ramp function (start after mains ON or with the binary function)</p>	<p>t1: Start (actual value)</p> <p>t2: Setpoint setting was reached</p>	<p>Firing curve (start with the binary function or using the function key)</p>	<p>t1: Start</p> <p>t2: SP1 -> SP2 (automatically)</p> <p>t3: Timer start</p> <p>t4: Timer end</p>
<p>LED (H): Is lit with the ramp function active</p>	<p>LED (H): Flashes in phase 1 (t1 to t2), is lit in phases 2 and 3 (t2 to t4)</p> <p>OFF (F): Firing curve not active</p>		

3 Operation - Configuration - Parameterization

3.1.4 Level concept

The parameters for device setting are organized at different **levels**.

(1) Changeover from normal display to the levels
(2) Changeover between levels
(3) Changeover to the operator level (setpoints, process values, timer value and time)
(4) Changeover to the parameter level (controller parameters)
(5) Changeover to configuration level (analog input, controller, ramp function, limit value monitoring, timer, outputs, binary functions, display and operation, interface)
(6) Return to the normal display
(10) Navigation principle:
(11) - one level deeper
(12) - next parameter / increase value
(13) - previous parameter / reduce value
(14) - one level back

If no key is pressed for 180 s (factory-setting), the device will return to its normal display. This time period can be configured.

The various levels are also accessible in manual mode.

Level inhibit (factory-setting: all levels are free):

Code	Operator level	Parameter level	Configuration level	
0	free	free	free	1. Simultaneously press (A) and (B) (> 5 s) 2. Press (A) (display flashes) 3. Enter code using (B) or (C) 4. Use (D) to return to the normal display (or automatically after 180 s) (key designation in brackets; see chapter 3.1.1)
1	free	free	inhibited	
2	free	inhibited	inhibited	
3	inhibited	inhibited	inhibited	

3.1.5 Operator level (OPR)

Depending on the configuration, the following parameters are available:

Symbol	Description	Symbol	Description
SP1	Setpoint 1 (can be edited)	rASL	Ramp rate (for firing curve; can be edited)
SP2	Setpoint 2 (can be edited)	SPr	Current ramp setpoint (for ramp function or firing curve)
t1	Timer value (if timer or firing curve are inactive; can be edited)	inP1	Measured value at analog input
tL	Timer run time (if timer or firing curve are active)	y	Output level
tR	Residual timer run time (if timer or firing curve are active)		

3 Operation - Configuration - Parameterization

3.2 Configuration (CONF)



TIP!

The device will map out parameters unless the equipment level permits the function assigned to the parameter. Factory settings appear in **bold** in the following table.

Analog selector

With some parameters in the configuration level, the user can choose from a series of analog values. The following list contains all available signals.

Value	Description	Value	Description
0	Switched off	7	Setpoint 2
1	Analog input	8	Output level display (-100 % to +100 %)
2	Actual value	9	Controller output 1 (e.g. heating, output level 0 to +100 %)
3	Current setpoint	10	Controller output 2 (e.g. cooling, output level 0 to -100 %)
4	Ramp end value	11	Timer run time (time unit of the timer)
5	(reserved)	12	Timer residual time (time unit of the timer)
6	Setpoint 1		

3.2.1 Analog input (InP)

[conf -> InP ->

Parameters	Value	Description	Value	Description	
Probe type SEn5		RTD temperature probe:		Thermocouples:	
	0	Pt100 3-wire	9	NiCr-Ni K	
	1	Pt1000 3-wire	10	Pt10Rh-Pt S	
	2	Pt100 2-wire	11	Pt13Rh-Pt R	
	3	Pt1000 2-wire	12	NiCrSi-NiSi N	
	4	KTY 2 wire	13	NiCr-CuNi E	
	5	Cu-50 3-wire		Standard signals:	
		Thermocouples:	14	0 to 20 mA	
	6	Cu-CuNi T	15	4 to 20 mA	
	7	Fe-CuNi J	16	0 to 10 V	
	8	Fe-CuNi L			
	When selecting "0 to 10 V", binary input $b_i n l$ is inactive.				

3 Operation - Configuration - Parameterization

Parameters	Value	Description
Measured value offset OFFS	-1999 ... 0 ... +9999	The measured value is corrected through this value (offset), prior to being used as a controller input value and in the analog selector.
Display start SCL	-1999 ... 0 ... +9999	On transducers with standard signal, a display value is assigned to the physical signal. Example: 0 to 20 mA = 0 to 1500 °C
Display end SCH	-1999 ... 100 ... +9999	
Filter time constant dF	0.0 ... 0.6 ... 100.0 (s)	Adaptation of the digital input filter (0 = Filter OFF)
Temperature unit Unit	1	deg. Celsius
	2	deg. Fahrenheit
(Setup program: Adjustable resistance of the KTY at 25 °C.)		

3.2.2 Controller (Cntr)

The actual value is provided for the controller by the analog input.

CONF -> Cntr ->

Parameters	Value	Description
Controller type CTYP	1	2-state controller
	2	3-state controller
	3	Continuous controller
Action ACT	0	Direct: (The output level of the controller is > 0 when the actual value exceeds the setpoint, e.g. cooling).
	1	Inverse: (The output level of the controller is > 0 when the actual value is smaller than the setpoint, e.g. heating.)
Output value, manual mode HAND	-100 ... 0 ... +101	Output level after switching to manual mode 101 = last output value
Output level at Out-of-Range rOut	-100 ... 0 ... +100	Output level in the event of overrange or underrange
Setpoint limit start SPL	- 1999 ... +9999	The setpoint limitation prevents the entry of values exceeding the default range.
Setpoint limit end SPH	-1999 ... +9999	The setpoint limits are not effective when entering setpoints via the interface. The correction value is limited for external setpoints with offset.
(Setup program: Manual mode and self-optimization can be inhibited.)		

3 Operation - Configuration - Parameterization

3.2.3 Ramp function/firing curve (rAFC)

The device can be operated as a fixed value controller with and without ramp function. In addition, a firing curve is supported.

[conf -> rAFC ->

Parameters	Value	Description
Function FnCt	0	Ramp function/firing curve switched off
	1	Ramp function Kelvin/Minute
	2	Ramp function Kelvin/Hour
	3	Ramp function Kelvin/Day
	4	Firing curve Kelvin/Minute
	5	Firing curve Kelvin/Hour
	6	Firing curve Kelvin/Day
Ramp rate rASL	0 ... 999	Value of the ramp rate (only for function = 1 to 6)

(Setup program: For the firing curve, timer value, time unit and setpoint can also be set here.)

3.2.4 Limit value monitoring (Li1, Li2)

The device is equipped with two functions for limit value monitoring (Li 1, Li 2) each with eight different alarm functions (AF1 to AF8). The two output signals are available for binary functions.

[conf -> L 1, L 2 ->

Parameters	Value	Description
Alarm function FnCt	0	Limit value monitoring switched off
	1	AF1: Limit value above and below the setpoint (monitoring range)
	2	AF2: As AF1, output signal inverted
	3	AF3: Limit value below the setpoint
	4	AF4: As AF3, output signal inverted
	5	AF5: Limit value above the setpoint
	6	AF6: As AF5, output signal inverted
	7	AF7: Fixed limit value (setpoint independent)
Limit value AL	-1999 ...	Limit value to be monitored
	0 ... +9999	Limit value range for AF1 and AF2: 0 to 9999
Hysteresis HYSL	0 ... 1 ... 9999	Hysteresis in respect to the limit value
Behavior at Out-of-Range ALrA	0	OFF
	1	On
		Switching state in the event of overrange or underrange ("Out-of-Range")

3 Operation - Configuration - Parameterization

Parameters	Value	Description
Switch-on delay t_{On}	0 ... 9999	Switch-on delay of the output signal (in seconds)
Actual value AFP_r	0	Signal to be monitored; 0 = switched off ⇒ "Analog selector", page 15
Setpoint $AFSP$	0	Setpoint for limit value monitoring (reference signal for AF1 to AF6); 0 = switched off ⇒ "Analog selector", page 15

3.2.5 Timer (tFct)

The timer provides an output signal available for the binary functions. This signal can be used, e.g. to realize a time-limited control or a time-dependent setpoint changeover.

The timer value is not saved during a mains failure. After the mains connection is restored, the timer remains inactive.

Conf -> tFct ->

Parameters	Value	Description
Function F_{nct}	0	Timer switched off
	1	Timer signal is "high" while the timer is running
	2	Timer signal is "low" while the timer is running
Start condition St_{rt}	0	Manual start via function key or binary signal (no restart after mains failure)
	1	Automatic start after mains ON (restart after mains failure); manual start is also possible
Time unit $U_{n t}$	0	mm:ss
	1	hh:mm
	2	hhh.h
Timer value t_l	00.00. ... 999.9.	Timer run time (in the time unit set)
Tolerance band t_{oLt}	0 ... 9999	Tolerance band for timer start The timer only starts once the actual value has reached the tolerance band. 0 = Start without tolerance band

3 Operation - Configuration - Parameterization

3.2.6 Outputs (OutL, OutA)

The configuration of the device outputs is subdivided in binary outputs (OutL) and analog output (OutA). The switching states of binary outputs 1 to 3 (5) are displayed by LEDs K1 to K3 (K5) (LED is lit = output active).

Binary outputs

The device is equipped with a relay output (N/O, output 1) as standard and can be optionally equipped with two (four) additional binary outputs (relay or logic output; outputs 2 to 5).

Conf -> OutL ->

Parameters	Value	Description
Output 1 ... 5	0	Output not active (factory setting for Out2 ... Out5)
Out1	1	Controller output 1 (factory setting for Out1)
Out2	2	Controller output 2
Out3	3	Binary input
Out4	4	Limit value monitoring 1
Out5	5	Limit value monitoring 2
	6	Timer signal

(Setup program: The output signal can be inverted.)

Analog output

The device can be optionally equipped with an analog output (output 2).

Conf -> OutA ->

Parameters	Value	Description
Function Funct	9	Function of the output; 9 = Controller output 1 ⇒ "Analog selector", page 15
Type of signal Sig		Physical output signal
	0	0 ... 20 mA
	1	4 ... 20 mA
	2	0 ... 10 V
Value at Out-of-Range rOut	0 ... 101	Signal (in percent) at overrange or underrange 101 = last output signal
Zero point OPnt	-1999 ... 0 ... +9999	Value range of the output variable for the physical output signal
End value End	-1999 ... 100 ... +9999	

3 Operation - Configuration - Parameterization

3.2.7 Binary functions (binF)

The binary signals of the binary output, the limit value monitoring and the timer can be used to trigger different functions.

The binary functions for start and abort react to the rising flank of the triggering signal, all other binary functions are state-dependent controlled and active with "High".

[conf -> binF ->

Parameters	Value	Description
Binary input bin1	0	Signal without function
	1	Start self-optimization
	2	Abort self-optimization
Limit value monitoring 1 and 2 L1, L2	3	Change to manual mode
	4	Switch off controller (controller outputs inactive)
	5	Switch on controller
	6	Inhibit manual mode
Timer signal tF1	7	Stop ramp/firing curve
	8	Abort ramp/firing curve
	9	Restart ramp, start/abort firing curve
	10	Switch over from setpoint 1 to setpoint 2
	11	Lock keypad
	12	Inhibit parameter and configuration level, inhibit self-optimization start
	13	Switch off the display
	14	Start timer
	15	Abort timer
	16	Stop timer
	17	Start/abort timer

3.2.8 Display and operation (diSP)

Both displays and the function key can be individually adapted to the respective requirements.

[conf -> diSP ->

Parameters	Value	Description
Upper display diSU	2	Display value for the upper display; 2 = Actual value ⇒ "Analog selector", page 15
Lower display diSL	3	Display value for the lower display; 3 = current set point value ⇒ "Analog selector", page 15

3 Operation - Configuration - Parameterization

Parameters	Value	Description
Display change when timer is started <i>dSt</i>		Time appears in the bottom display once the timer is started
	0	No display change
	1	Residual timer time
	2	Timer run time
Time-out <i>tout</i>	0 ... 180 ... 255	Time period in seconds, after which the device automatically returns to its normal display (if no key is pressed). 0 = Function switched off
Decimal place <i>dECP</i>	0	No decimal place
	1	One decimal place
	2	Two decimal places
Function key, press briefly (< 2 s) <i>tAS</i>	0	No function
	1	Start timer/firing curve
	2	Abort timer/firing curve
	3	Stop/continue timer/firing curve run
	4	Start/abort timer/firing curve
	5	Timer display (timer run time or residual timer time)
(Setup program: The function of pressing the function key longer (> 2 s) can also be configured.)		

3.2.9 Interface (IntF)

An optional RS485 interface can be used to integrate the device in a data network. When the communication takes place via the setup interface, the RS485 interface is inactive.

Conf -> IntF ->

Parameters	Value	Description
Baud rate <i>bdr</i>	0	9600 baud
	1	19200 baud
Device address <i>Adr</i>	0 ... 1 ... 254	Address in data network

For further information about the RS485 interface, the Modbus protocol and the communication with other devices, please refer to the interface description B 702020.2.0 available as a PDF document under www.quantrol.org.

3 Operation - Configuration - Parameterization

3.3 Parameterization (PARA)

Enter the controller parameters here.

PARA ->

Parameters	Value	Description
Proportional band P_{b1}, P_{b2}^1	0 ... 9999	Range of the proportional band The larger the proportional band the lower the controller amplification. The controller structure is not effective with $P_b = 0$ (behavior identical to limit value monitoring). For the continuous controller, ensure that P_b is > 0 .
Derivative time d_t	0 ... 80 ... 9999 (s)	Influences the differential portion of the controller output signal The larger the derivative time the higher the effectiveness of the D portion. 0 = derivative time switched off (no D portion)
Reset time r_t	0 ... 350 ... 9999 (s)	Influences the integral portion of the controller output signal The larger the reset time the lower the effectiveness of the I portion. 0 = reset time switched off (no I portion)
Cycle time C_{y1}, C_{y2}^1	0.0 ... 20.0 ... 999.9 (s)	When using a switched output, the cycle time should be chosen so that the energy flow to the process is as continuous as is practicable without overloading the switching elements.
Contact spacing d_b	0.0 ... 999.9	Spacing between the two control contacts of a 3-state controller
Hysteresis H_{y1}, H_{y2}^1	0.0 ... 1.0 ... 999.9	Hysteresis for a switching controller with proportional range $P_b = 0$ (behavior identical to that for limit value monitoring)
Working point y_0	-100 ... 0 ... +100	The output level for P and PD controllers (if $x = w$ then $y = y_0$)
Output level limiting y_1, y_2	0 ... 100 (%)	y1: Maximum output level limitation
	-100 ... +100 (%)	y2: Minimum output level limitation (only effective when $P_b > 0$)

¹ Only available for 3-state controllers (controller output 2)

The display of parameters depends on the controller type. For some parameters, the decimal place depends on the device setting.

Factory settings appear in **bold**.

4.1 Additional information about installation



TIP!

The information given in this chapter is exclusively contained in this operating manual provided as PDF document. It supplements the information contained in the previous chapters of this operating manual as well as in the brief instructions added to every device as a print out.

The ambient conditions at the installation site must meet the requirements specified in the technical data.

The device is not suitable for installation in explosive areas (Ex areas).

4.1.1 Device representation including dimensions

LC100

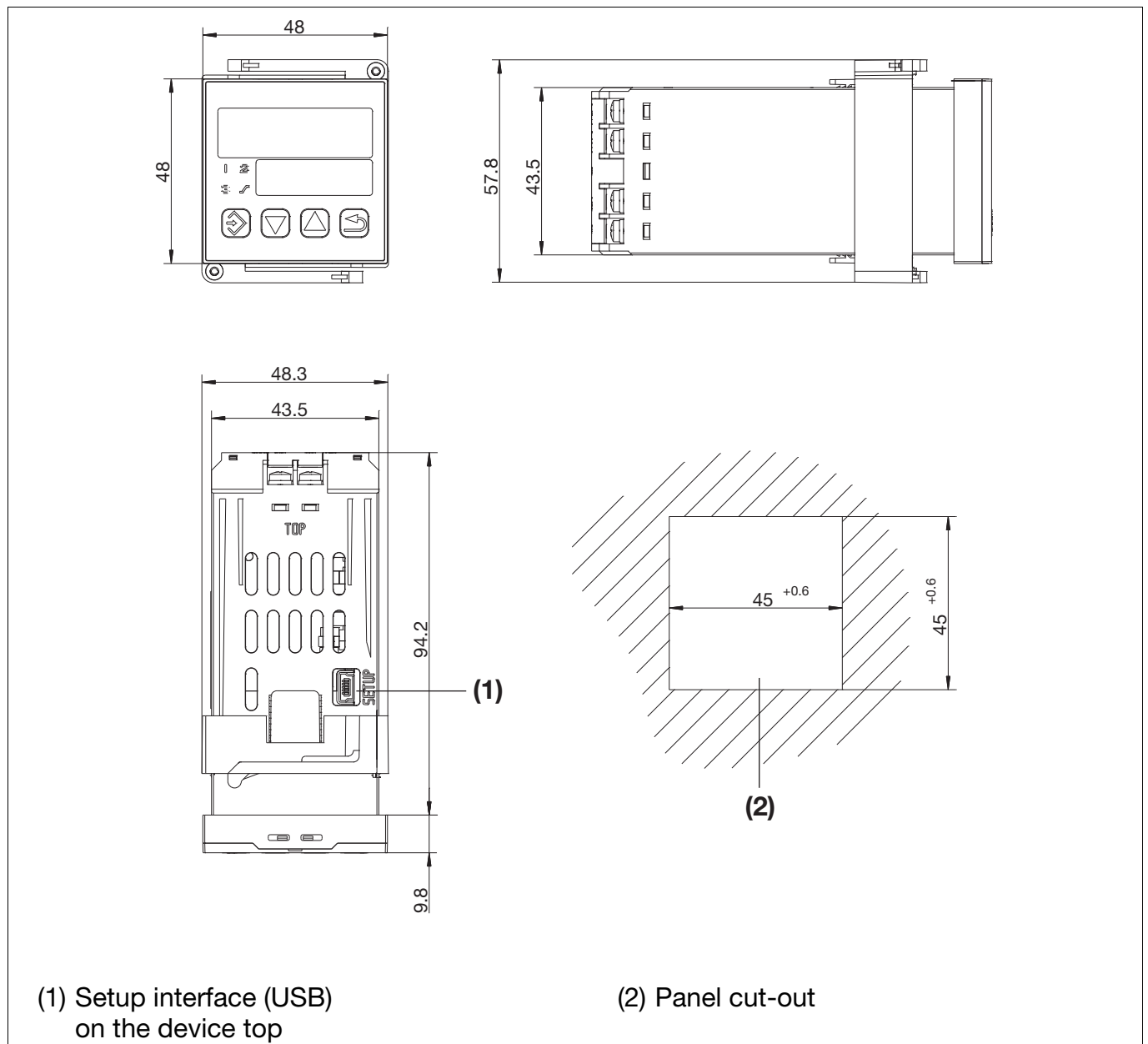

4 Supplement

LC200

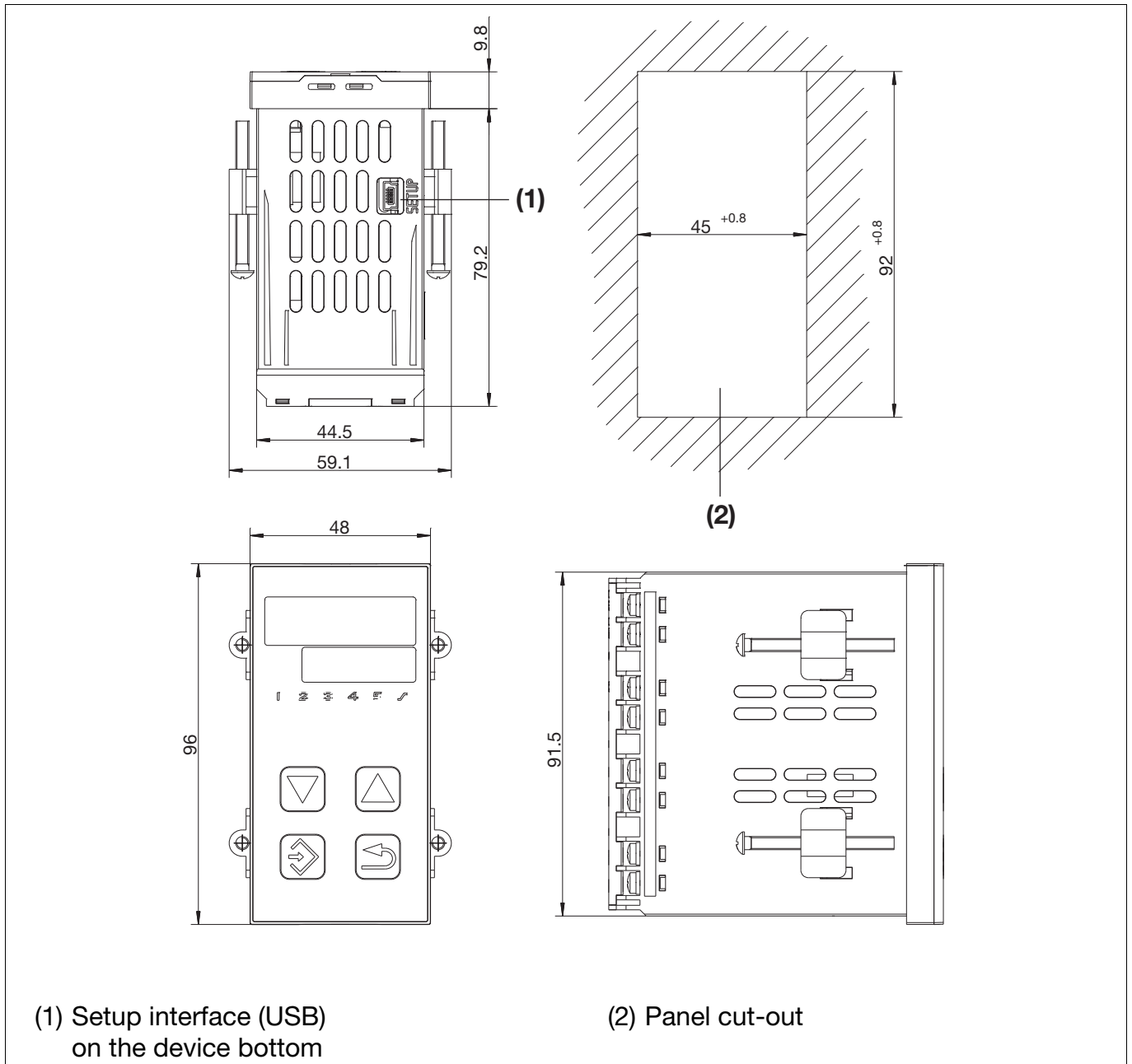

LC300

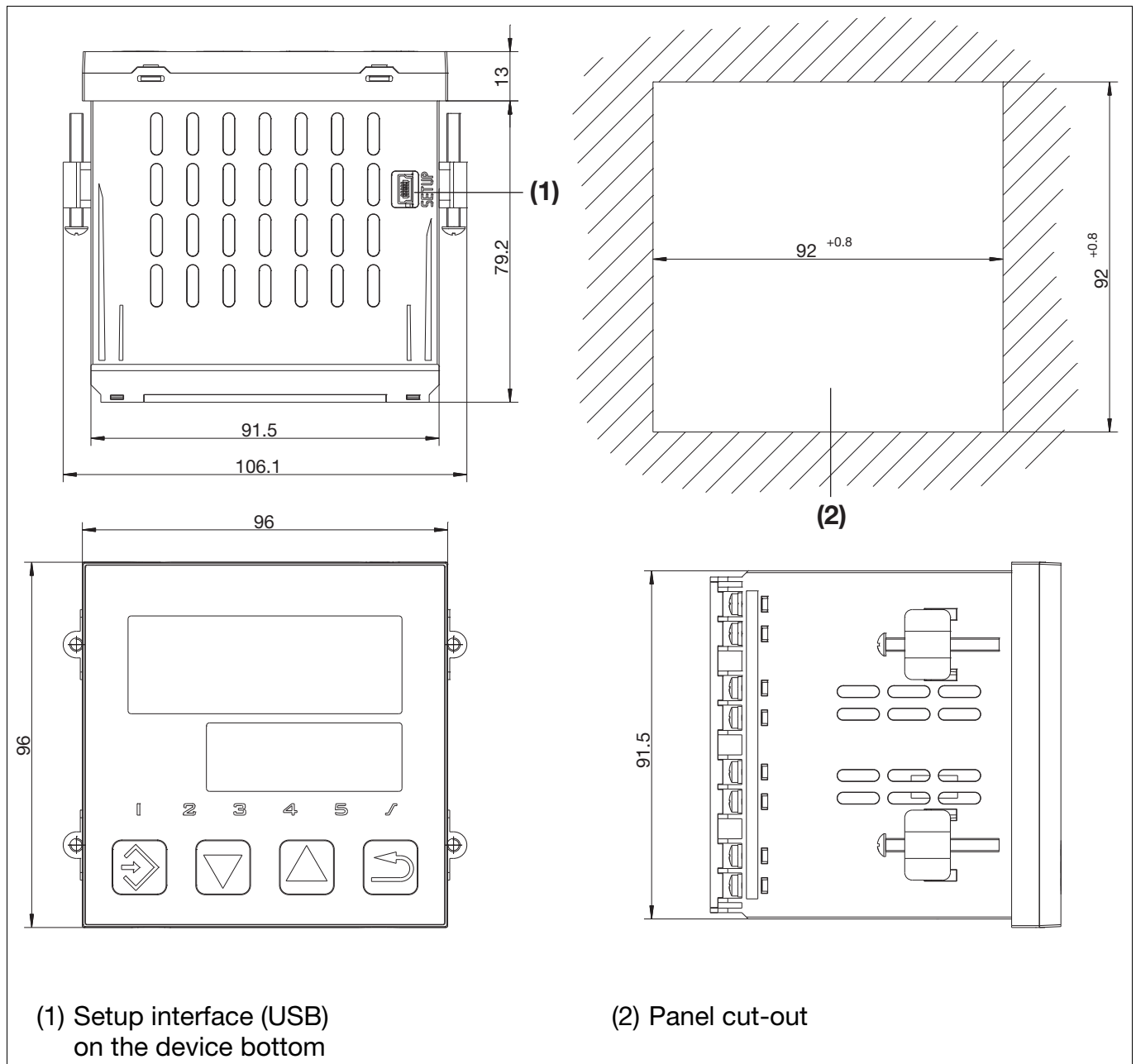

Minimum spacing of panel cut-outs

Type	without USB cable		with USB cable	
	horizontal	vertical	horizontal	vertical
LC100	11 mm	30 mm	11 mm	65 mm
LC200	22 mm	30 mm	22 mm	65 mm
LC300	22 mm	30 mm	22 mm	65 mm

4.1.2 Cleaning the device front

The device front panel can be cleaned with commercial cleaning and rinsing agents. It has a limited resistance to organic solvents (such as ethyl alcohol, turpentine substitute, P1, xylol and similar). Do not use high-pressure cleaning equipment.

4 Supplement

4.2 Additional information about the device functions



TIP!

The information given in this chapter is exclusively contained in this operating manual provided as a PDF document. It supplements the information contained in the previous chapters of this operating manual as well as in the brief instructions added to every device as a print out.

4.2.1 Entries and operator prompting

Value entry

When entries are made within the levels, the parameter symbol appears in the lower display.

(1) Select parameter (lower display - green)
(2) Change value (upper display - red)
(3) Parameter flashes

Time entry

A decimal place is mapped in the centre and on the right to display times. The time unit can be configured.

(1) Select parameter (lower display - green)
(2) Change value (upper display - red)
(3) Parameter flashes

Procedure

1.	Select parameter with key (B) or (C)
2.	Change-over to the input mode with key (A): The lower display flashes.
3.	Change value with key (B) or (C) The longer the key is kept pressed, the faster the value changes.
4.	Apply setting with key (A) (value is automatically applied after 2s) - or cancel entry using key (D) (value will not be applied)



TIP!

When pressing function key (D) for more than 2 seconds, the device will return to the normal display

4.2.2 Analog input

Measured value offset

A measured value correction (offset) can be carried out to correct system specific deviations. The offset value is added to the measured value with the correct prefix (the measured value is reduced by entering a negative offset value).



CAUTION!

Measured value offset: The controller uses the corrected value for calculation (= displayed value). When the measured value has been offset, the corrected value does no longer correspond to the value measured at the measuring point. Incorrect use can cause inadmissible values of the control variable. Only carry out a measured value offset within the admissible range.

Filter time constant

The filter time constant serves to adapt the digital input filter (filter of second priority). At a step change of the input signal, approx. 26 % of the change is detected after the elapse of a time period corresponding to the filter time constant dF ($2 \times dF$: approx. 59 %; $5 \times dF$: approx. 96 %).

A high filter time constant means:

- High damping of interference signals
- Slow reaction of the actual value display to actual value changes
- Low limit frequency

4.2.3 Analog output

Zero point and end value

The factory setting corresponds to an output level of 0... 100 % for the continuous controller (controller output 1): zero point = 0, end value = 100

If the analog output is used as controller output 2 for the 3-state controller (e.g. for cooling), the following setting is required: zero point = 0, end value = -100

If, for example, the actual value is to be put out, which can be within the range of 150 °C to 500 °C, select the limits so that they correspond to the minimum and maximum temperature: zero point = 150, end value = 500

4 Supplement

4.2.4 Ramp function and firing curve

Ramp function

This function allows the continuous change of the setpoint up to the ramp end value (setpoint setting $SP1$ or $SP2$). Depending on the actual value at ramp start, this results in a rising or falling ramp with identical gradient (adjustable ramp ratio $rASL$).

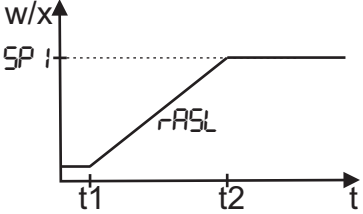
	<p>The ramp starts after mains ON (or through the binary function) at time $t1$ and starts at the actual value. The setpoint $SP1$ (or $SP2$) is moved to at ramp ratio $rASL$ and is reached at time $t2$.</p> <p>When switching over or changing the setpoint, the new setpoint is also moved to at ramp ratio $rASL$.</p>
<p>LED "Ramp" (H): Is lit with active ramp function (until it is cancelled)</p>	<p>The ramp can be stopped or aborted using the binary function. When aborted, the setpoint setting $SP1$ (or $SP2$) is used to control.</p>



TIP!

The ramp function is interrupted in the event of a probe break, probe short-circuit, overrange/underrange or changeover to manual mode. Once the event is remedied (or after switching to automatic mode), the ramp function continues at the current actual value.

After the power supply is restored, the ramp function starts at the current actual value.

Firing curve

For use in small kilns, a firing curve can be saved for controlled start-up and time-dependent firing.

With this function, the parameters setpoint 1 ($SP1$), setpoint 2 ($SP2$), ramp rate ($rASL$) and timer value (t) are automatically linked to each other.

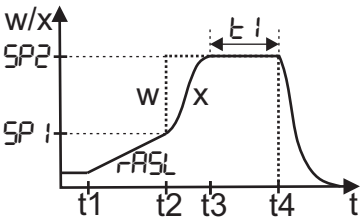
	<p>Phase 1 ($t1$ to $t2$): The firing curve is started by using the function key or with the binary function (time $t1$) and starts at the actual value. The setpoint $SP1$ is moved to at ramp ratio $rASL$.</p>
<p>LED "Ramp" (H): Flashes in phase 1, is lit in phase 2 and 3</p>	<p>Phase 2 ($t2$ to $t3$): Once the actual value has reached the setpoint $SP1$ ($t2$), the device automatically switches over to setpoint $SP2$ (w). The actual value (x) approaches the new setpoint (the ramp ratio is of no importance).</p> <p>Phase 3 ($t3$ to $t4$): The timer starts when the actual value has reached the setpoint $SP2$ ($t3$) and keeps running for the set time (timer value t). Once the timer has elapsed ($t4$), the controller switches off (setpoint display = 0).</p>



TIP!

The firing curve can only be started when the actual value is smaller than setpoint 1. The firing curve is aborted in the event of a probe break, probe short-circuit, over-range/underrange or change-over to manual mode (controller switched off). After the power supply is restored, the firing curve is not active (controller switched off). When the firing curve is not active, **OFF** appears in the lower display.

4.2.5 Timers

The following functions can be realized when using the binary functions.

Time-limited control

The control is switched off once the timer has elapsed (output level 0 %).

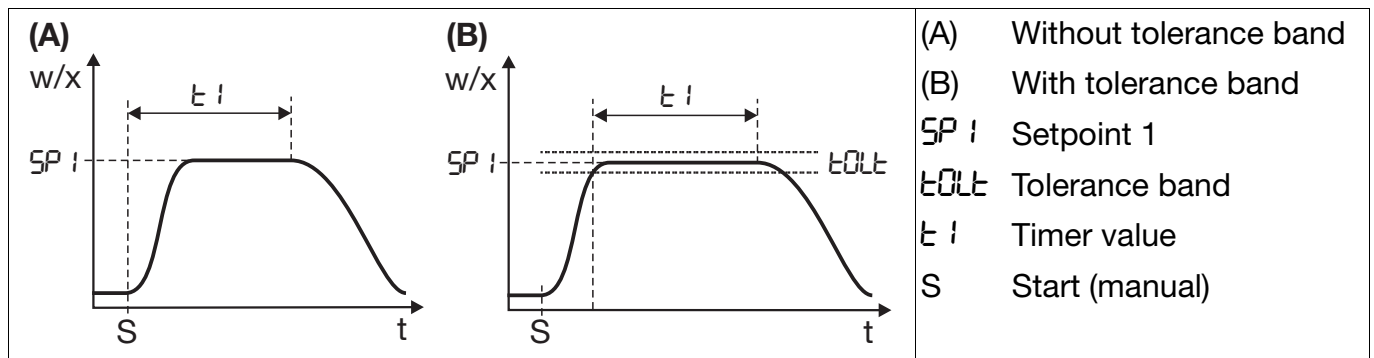

Time-dependent setpoint changeover

After the timer is started, the controller is automatically set to setpoint SP2. Once the timer has elapsed, the controller automatically switches to SP1.

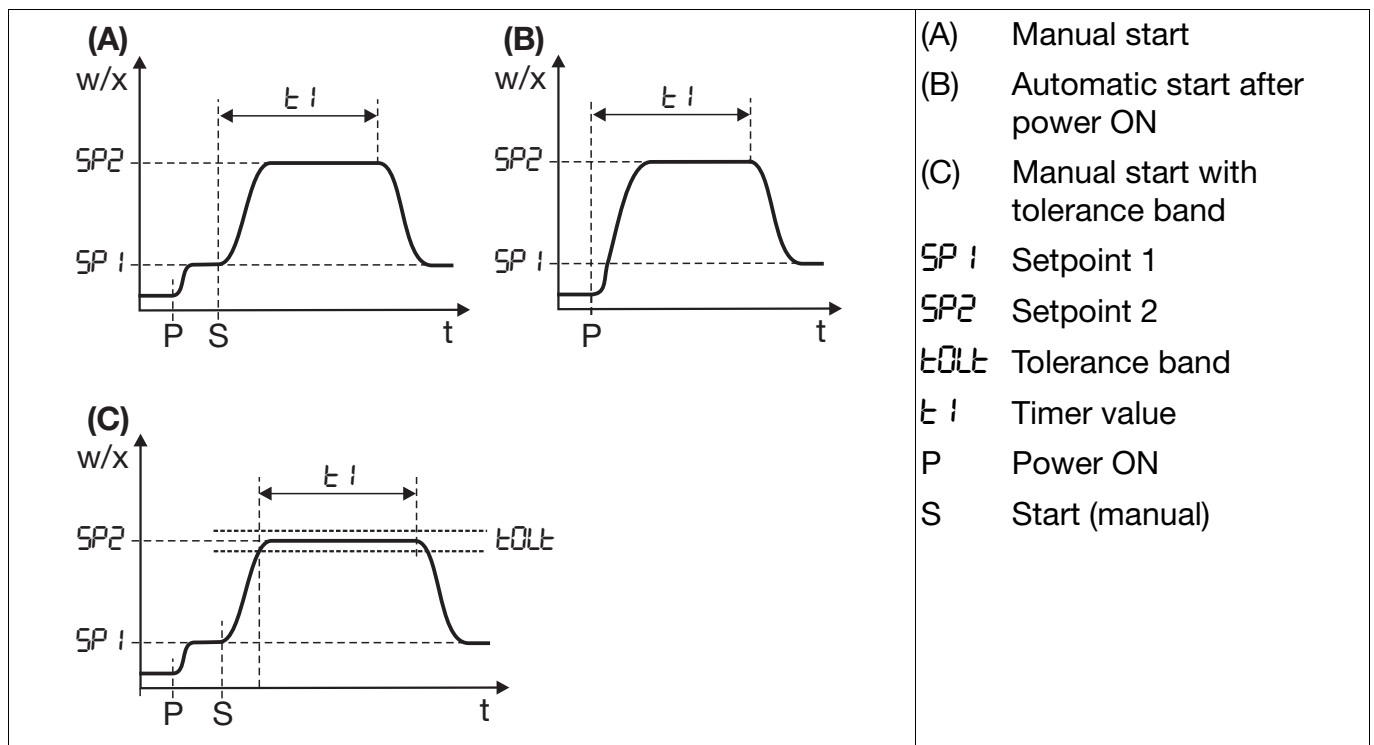

4 Supplement

4.2.6 Limit value monitoring

The following representations show the function of limit value (AL) for the various alarm functions AF1 to AF8. The hysteresis (HySt) is always symmetrical in relation to the limit value.

Limit value AL referring to setpoint w

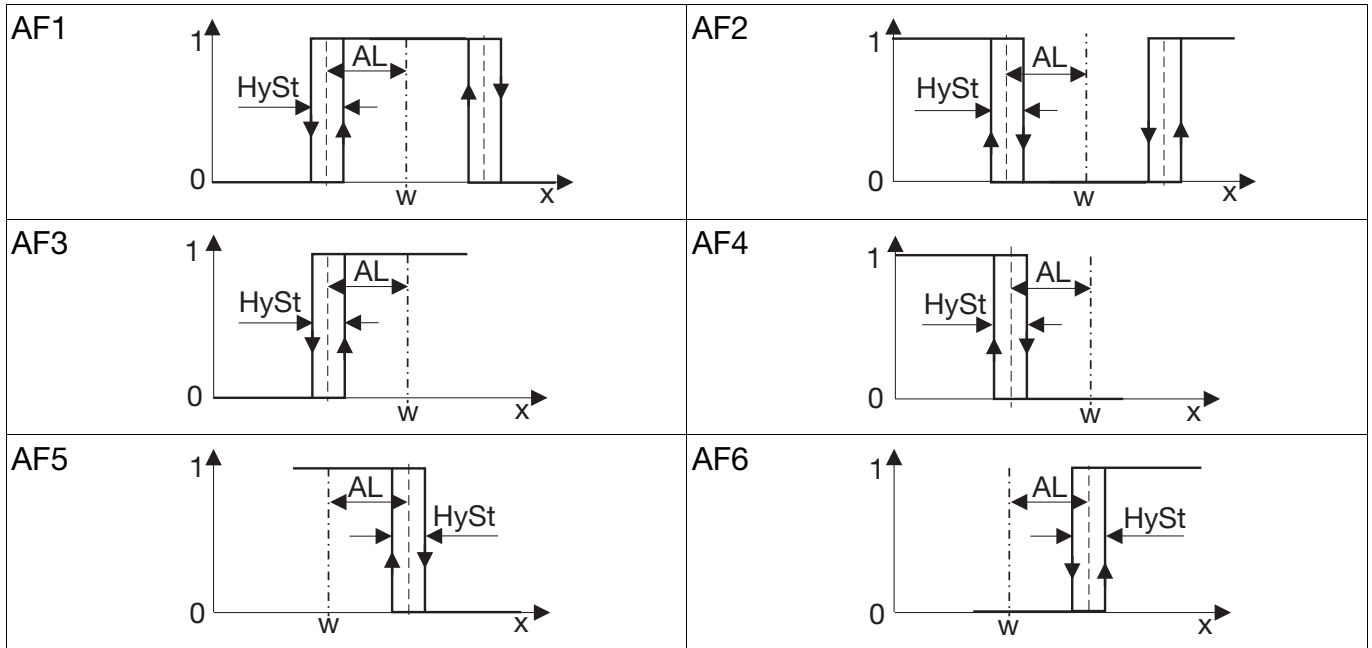

Fixed limit value AL

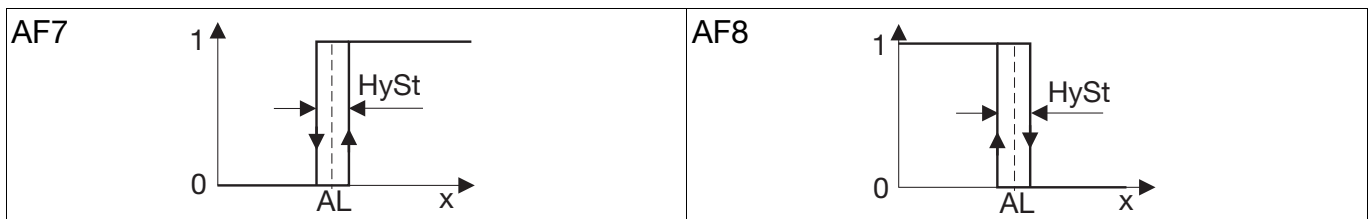

4.2.7 Self-optimization (TUNE)

Self-optimization operates according to the oscillation method and determines the optimum parameters for a PID or PI controller.

The following parameters are optimized depending on the controller type configured (2-state, 3-state, continuous controller) and the controller structure (parameterization):

Proportional band (Pb1, Pb2), derivative time (dt), reset time (rt), cycle time (Cy1, Cy2), filter time constant (dF; parameter of the analog input).

Depending on the value of the control deviation, the controller selects between two self-optimization methods:

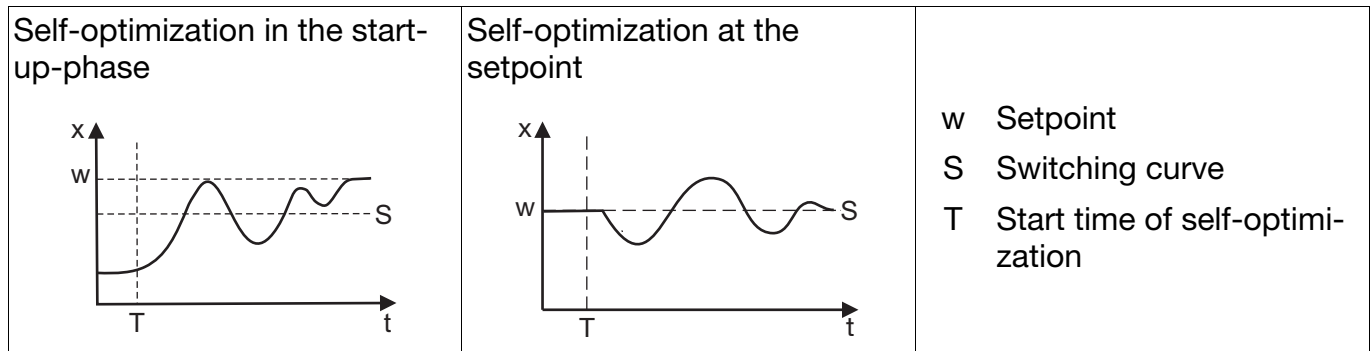

Prerequisites

The following prerequisites must be fulfilled to be able to start self-optimization:

- Self-optimization start is not inhibited by the binary function (binF)
- Controller is in the automatic mode, not in the manual mode
- No parameter level inhibit active via setup program
- Ensure that keys (B) and (C) are not pressed one after the other. They must always be pressed simultaneously.

Furthermore, the following points should be taken into consideration, checked and, if necessary, adjusted, prior to starting self-optimization:

- Is the suitable controller type configured?
- Check and/or adjust the control action of the controller
- Is it possible to sufficiently influence the actual value in the manual mode?
- Only for continuous controller: The function of the output (OutP -> OutA) must be configured as controller output 1 and scaled to 0 ... 100 %. This means:
Function (FnCt) = Controller output 1 (9)
Zero point (0Pnt) = 0
End value (End) = 100

Depending on the controller type and parameter setting, the controller structures and specific parameters are optimized:

Controller type	Parameter setting	Optimized controller structure	Optimized parameters
2-state controller	rt > 0; dt = 0; Pb1 = any	PI	Pb1, rt, Cy1, dF
	all other settings	PID	Pb1, dt, rt, Cy1, dF
3-state controller	rt > 0; dt = 0; Pb1 = Pb2 = any	PI	Pb1, Pb2, rt, Cy1, Cy2, dF
	all other settings	PID	Pb1, Pb2, dt, rt, Cy1, Cy2, dF
Continuous controller	rt > 0; dt = 0; Pb1 = any	PI	Pb1, rt, dF
	all other settings	PID	Pb1, dt, rt, dF

4 Supplement

Start of self-optimization

Simultaneously press keys (B) and (C) (> 2 s):

"tUnE" flashes in the lower display.

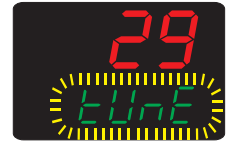

Self-optimization is completed when the display automatically changes to the normal display. The duration of self-optimization depends on the control process.

Abort of self-optimization

Simultaneously press keys (B) and (C)

No parameters are changed by the abort.

4.3 Error messages

Display	Cause	Fault remedy
- 1999 (flashing!)	Underrange of the displayed value.	Is the medium being measured within the range (too hot? too cold?)
9999 (flashing!)	Overrange of the displayed value.	Check probe for break and short-circuit. Check the probe connection and the terminals. Check cable. Check that the connected probe complies with the configured probe type
PErr	Firing curve start is impossible because the actual value is \geq than the setpoint 1	The firing curve can be started when the actual value is $<$ than the setpoint 1

Overrange / underrange covers the following events:

- Probe break/short-circuit
- Measured value outside the probe measuring range
- Display overflow

No keyboard operations are possible during device initialization (all displays are switched on, the upper 7-segment display flashes).

4 Supplement

4.4 Technical Data

Thermocouple input

Designation	Standard	Measuring range ^a	Measuring accuracy ^b	Ambient temperature influence
Fe-CuNi „L“		-150 to +900 °C	≤ 0.4 %	≤ 100 ppm/K
Fe-CuNi „J“	EN 60584	-200 to +1200 °C	≤ 0.4 %	≤ 100 ppm/K
Cu-CuNi „T“	EN 60584	-200 to +400 °C	≤ 0.4 %	≤ 100 ppm/K
NiCr-Ni „K“	EN 60584	-200 to +1372 °C	≤ 0.4 %	≤ 100 ppm/K
NiCr-CuNi „E“	EN 60584	-200 to +1000 °C	≤ 0.4 %	≤ 100 ppm/K
NiCrSi-NiSi „N“	EN 60584	-100 to +1300 °C	≤ 0.4 %	≤ 100 ppm/K
Pt10Rh-Pt „S“	EN 60584	-40 to +1768 °C	≤ 0.4 %	≤ 100 ppm/K
Pt13Rh-Pt „R“	EN 60584	-40 to +1768 °C	≤ 0.4 %	≤ 100 ppm/K
Cold junction: KTY internal				

^a The specifications refer to an ambient temperature of 20°C.

^b Including measuring accuracy at the internal cold junction.
The accuracy values refer to the measuring range.

RTD temperature probe input

Designation, connection type	Measuring range	Measuring accuracy ^a	Ambient temperature influence
Pt100 DIN EN 60751 2-wire connection 3-wire connection	-200 to +650 °C	≤ 0.4 % ≤ 0.4 %	≤ 50 ppm/K
Pt1000 DIN EN 60751 2-wire connection 3-wire connection	-200 to +650 °C	≤ 0.4 % ≤ 0.4 %	≤ 50 ppm/K
KTY, R ₂₅ = 1000 Ω 2-wire connection	-50 to +150 °C	≤ 1.0 %	≤ 50 ppm/K
KTY, R ₂₅ = 2000 Ω 2-wire connection	-50 to +80 °C	≤ 1.0 %	≤ 50 ppm/K
Cu-50 3-wire connection	-50 to +200 °C	≤ 1.0 %	≤ 50 ppm/K
Probe wire resistance: max. 30Ω per wire with 3-wire circuit			
Measured current: Pt100 approx. 1 mA; Pt1000 and KTY approx. 100 μA			
Lead compensation: Not required for 3-wire circuit. For a 2-wire circuit, the lead resistance can be compensated by correcting the actual value.			

^a The accuracy values refer to the measuring range.

Input for standard signals

Measuring range	Measuring accuracy ^a	Ambient temperature influence
Voltage 0 to 10 V Input resistance > 650 kΩ	≤ 0.4 %	≤ 150 ppm/K
Current 0(4) to 20 mA voltage drop > 2.2 V	≤ 0.4 %	≤ 100 ppm/K

^a The accuracy values refer to the maximum measuring range.

Binary input

Input for potential-free contact	open = inactive; closed = active
----------------------------------	-------------------------------------

Measuring circuit monitoring

In the event of a fault, the outputs adopt a defined (configurable) status.

Measuring probe	Overrange / underrange	Probe / cable short circuit	Probe / cable break
Thermocouple	•	-	•
RTD temperature probe	•	•	•
Voltage 0 to 10V	-	-	-
Current 4 to 20 mA	•	•	•
Current 0 to 20 mA	-	-	-

• = detected - = not detected

Outputs

Relay (N/O) Contact rating Contact life	max. 3 A at 230 V AC resistive load 150,000 operations at nominal load 350,000 operations at 1 A 310,000 operations at 1 A and $\cos\varphi > 0.7$
Logic output	0/14V / 20mA max.
Voltage (option) Output signal Load resistance Accuracy	0 to 10V > 600 Ω < 0.5 %
Current (option) Output signals Load resistance Accuracy	0 to 20 mA / 4 to 20 mA < 450 Ω < 0.5 %

4 Supplement

Controller

Controller type	2-state controller, 3-state controller, continuous controller
Controller structures	P/PI/PD/PID
Sampling time	250 ms
A/D converter	16 bit resolution

Timers

Accuracy	0.8 % \pm 10 ppm/K \pm 250 ms
----------	-----------------------------------

Electrical data

Voltage supply (switch mode PSU)	AC 110 to 240V +10/-15 %, 48 to 63Hz AC/DC 20 to 30V, 48 to 63Hz
Electrical safety	as per DIN EN 61010, part 1 overvoltage category III, pollution degree 2
Power consumption	max. 14 VA
Electrical connection	on the rear via screw terminals; with core-end ferrule of a pipe shape, open cable lug or pin cable lug
Conductor cross section	fine-strand up to max. 1.5 mm ²
Tightening torque	0.5 Nm
Electromagnetic compatibility	as per DIN EN 61326-1
Interference emission	Class A - Only for industrial use -
Interference immunity	Industrial requirements
Setup interface	USB socket, type Mini-B 5-pole

Requirements for core-end ferrules and cable lugs

Core-end ferrule	pipe shape, without plastic sheath as per DIN 46228 part 1, with plastic sheath as per DIN 46228 part 4
Cable lug	open crimp cable lug, dimensionally adapted to DIN 46237 for closed crimp cable lugs
Pin cable lug	as per DIN 46231

Case

Case type	plastic case for panel mounting as per IEC 61554
Dimensions (front)	LC100: 48 mm x 48 mm; LC200: 48 mm x 96 mm (portrait format); LC300: 96 mm x 96 mm
Panel cut-out	LC100: 45 mm x 45 mm; LC200: 45 mm x 92 mm; LC300: 92 mm x 92 mm
Minimum spacing horizontal / vertical	LC100: 11 mm / 30 mm (65 mm with USB cable); LC200/LC300: 22 mm / 30 mm (65 mm with USB cable)
Depth behind panel	LC100: max. 95 mm; LC200/LC300: max. 80 mm
Ambient / storage temperature range	-5 to +55 °C / -40 to +70 °C
Ambient conditions	rel. humidity < 90% annual average, without condensation
Operating position	any

Protection type	as per DIN EN 60529, at the front IP 65, at the rear IP 20
Weight (fully equipped)	LC100: approx. 150 g; LC200: approx. 200 g; LC300: approx. 300 g

Interface

Interface type	RS485
Protocol	Modbus RTU
Baud rate	9600, 19200
Data format	8 data bits, no parity bit, 1 stop bit
Device address	0 to 254
No. of subscribers	max. 32

7-segment displays

Digit height	
LC100, LC200	upper display: 10 mm; lower display: 7 mm
LC300	upper display: 20 mm; lower display: 13 mm
Color	upper display: red; lower display: green
Places	4 (including decimal places)
Decimal places	0, 1, 2 (configurable)
Display range	-1999 to 9999

Approvals/approval marks

Approval marks	Inspection authority	Certificate / Inspection number	Inspection/test basis	valid for
c UL us	Underwriters Laboratories	applied for	UL 61010-1, CAN/CSA C22.2 No. 61010-1	all versions

E-mail: info@quantrol.org
Internet: www.quantrol.org

Technical support:
Phone: +86 411 8718 9010-198
Fax: +86 411 8718 9020
E-mail: info@jumo-china.com